



**NATIONAL
SENIOR CERTIFICATE**

GRADE 12

SEPTEMBER 2023

PHYSICAL SCIENCES P1

MARKS: 150

TIME: 3 hours

Font size 18

This question paper consists of 27 pages
including a 3-page data sheet.

INSTRUCTIONS AND INFORMATION

1. Write your full NAME and SURNAME in the appropriate spaces on the ANSWER BOOK.
2. Answer ALL the questions.
3. You may use a non-programmable calculator.
4. You may use appropriate mathematical instruments.
5. Number the answers correctly according to the numbering system used in this question paper.
6. You are advised to use the attached DATA SHEETS.
7. Show ALL formulae and substitutions in ALL calculations.
8. Give brief motivations and discussions where required.
9. Round off your FINAL numerical answers to a minimum of TWO decimal places.
10. Start EACH question on a NEW page.
11. All diagrams are NOT necessarily drawn according to scale.
12. Write neatly and legibly.

QUESTION 1: MULTIPLE-CHOICE QUESTIONS

Various options are provided as possible answers to the following questions. Choose the answer and write only the letter (A–D) next to the question numbers (1.1 to 1.10) in the ANSWER BOOK, for example 1.11 E.

1.1 Which ONE of the following quantities is a measure of the inertia of a body?

A Acceleration

B Energy

C Velocity

D Mass

(2)

1.2 The velocity-time graph below represents the motion of an object under the influence of gravitational force only.

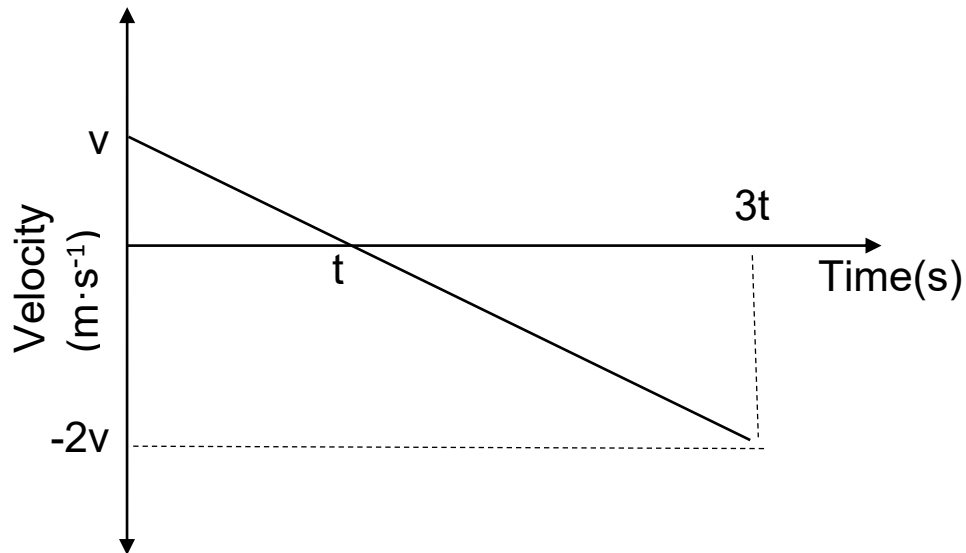

The displacement of the object at time 3t is ...

A $vt.$

B $-vt.$

C $\frac{-3}{2} vt.$

D zero.

(2)

1.3 Airbags can protect a driver from serious injury during a collision.

Which ONE of the following combinations in the table below best describes the effect that airbags have on the contact time and the net force acting on the driver during the collision and explains why the driver is more protected from injury?

	CONTACT TIME	NET FORCE
A	Increases	Increases
B	Increases	Decreases
C	Decreases	Increases
D	Decreases	Decreases

(2)

1.4 An object is projected vertically upwards from the ground and reaches a maximum height h . Which ONE of the following statements regarding the movement of the object from the ground to height h is correct?

Ignore the effects of air friction.

A The mechanical energy of the object at height h is zero.

B The change in kinetic energy of the object is zero.

C The loss in the object's kinetic energy is equal to the gain in the object's gravitational potential energy.

D The work done on the object is equal to zero. (2)

1.5 The force on gravitational attraction on the earth is 6 times greater than on the moon. The reason for this is:

- A The moon has no water on its surface.
- B The mass and the radius of the earth is greater than that of the moon.
- C Only the mass of the earth is greater than the mass of the moon.
- D Only the radius of the earth is greater than the radius of the moon. (2)

1.6 An observer moving at a constant speed away from a stationary sound source, observes that the pitch of the sound waves decreases. This is because the following happens:

	WAVELENGTH	FREQUENCY
A	Increases	Decreases
B	Decreases	Remains the same
C	Increases	Increases
D	Decreases	Increases

(2)

1.7 Three identical positive point charges, Q_1 , Q_2 and Q_3 , are arranged as shown in the diagram below.

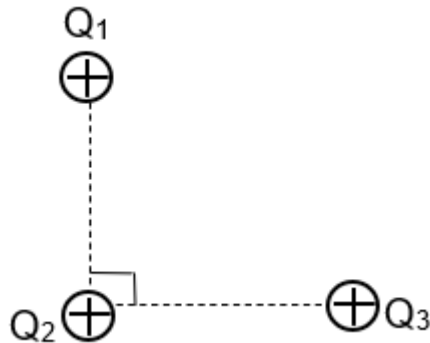

Which ONE of the following diagrams is the correct representation of the NET electrostatic force experienced by charge Q_2 ?

A		B	
C		D	

(2)

1.8 In the circuit diagram below, light bulbs **X** and **Y** are identical. Switch **S** is open.

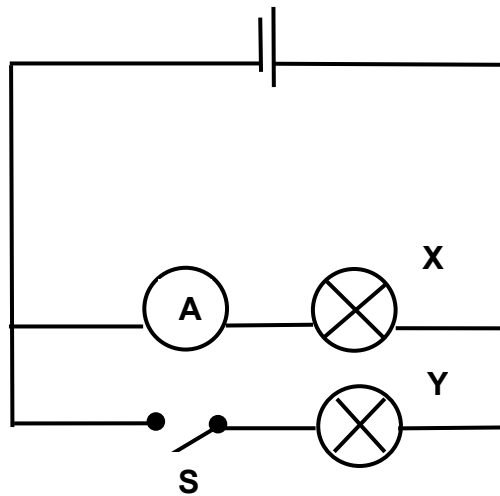

Switch **S** is now closed.

Which ONE of the following combinations below best describes the change in the total resistance of the circuit and the ammeter reading when switch **S** is closed?

	TOTAL RESISTANCE	AMMETER READING
A	Increases	Decreases
B	Increases	Remains the same
C	Decreases	Increases
D	Decreases	Remains the same

(2)

1.9 A lamp is connected to an AC generator, and it glows with the same brightness as when it is connected to a DC generator producing a potential difference of Y volts. The power dissipated by the lamp when connected to the AC generator is equal to ...

A $\frac{Y}{\sqrt{2}} (I_{\text{MAX}})$.

B $\frac{1}{2} I_{\text{max}}(Y)$.

C $I_{\text{max}} (Y)$.

D $\frac{Y}{\sqrt{2}} (I_{\text{rms}})$.

(2)

1.10 The graph below shows the relationship between maximum kinetic energy of ejected photo-electrons and the frequency of the incident photon.

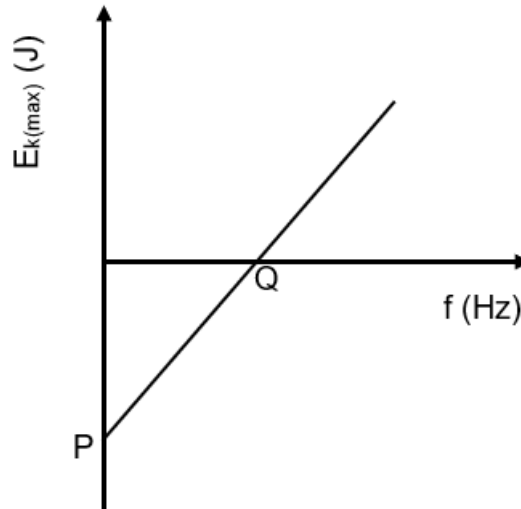

What do the intercepts **P** and **Q** on the graph represent?

	INTERCEPT P	INTERCEPT Q
A	Planck's constant	Threshold frequency
B	Threshold frequency	Work function
C	Work function	Threshold frequency
D	Threshold frequency	Planck's constant

(2)
[20]

QUESTION 2

A truck of mass 1 300 kg is connected to a car of mass 950 kg by means of an inextensible, massless rope, **R**, and pulls the car along a straight horizontal rough road. The engine of the truck applies a force of 9 000 N to move the truck-car combination to the left as shown in the diagram below. The truck experiences a constant frictional force of 3 500 N. The truck and car move at a **CONSTANT VELOCITY**.

Ignore the rotational effects of the wheels.

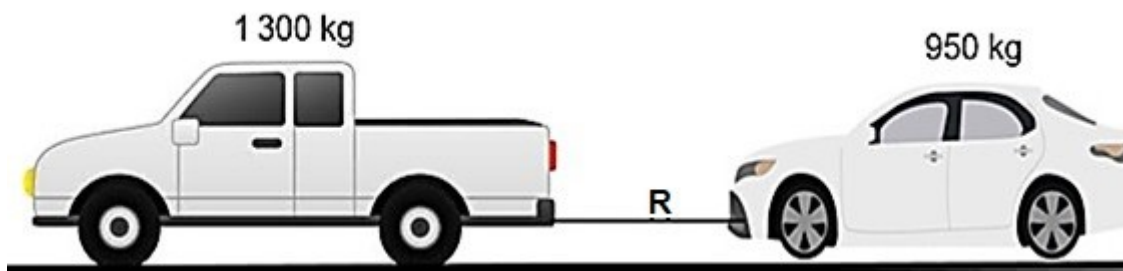

2.1 A learner states that if the truck comes to a sudden stop, the car will continue moving at a constant velocity.

Which physics law did this learner apply to make this statement? (1)

2.2 Draw a labelled free-body diagram of all forces acting on the truck. (5)

2.3 Calculate the:

2.3.1 Tension in the rope connecting the truck and the car (3)

2.3.2 The coefficient of kinetic friction between the car and the road (4)

2.4 The rope between the truck and the car suddenly breaks and the car continues to move to the left before coming to rest.

Calculate the magnitude of the acceleration of the car after the rope breaks. (3)
[16]

QUESTION 3

A group of learners set up an experiment to determine the height h of their school. They release a tennis ball from point **A** at the edge of the roof of the school building as shown in the diagram below. Point **B** is 2 m above the ground and the ball takes 0,125 s to cover the distance from point **B** to the ground (point **C**).

Ignore the effects of air friction.

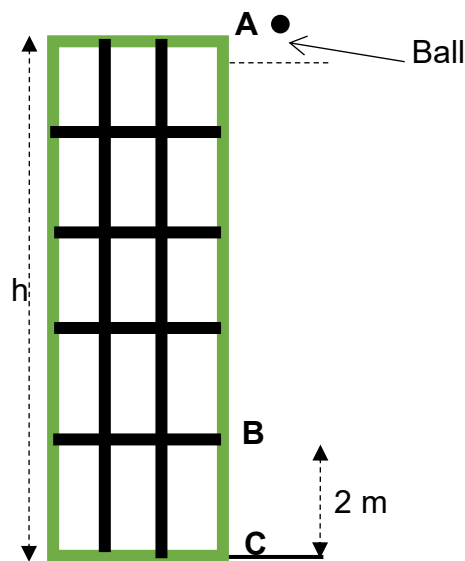

- 3.1 Write down the magnitude of the rate of change of velocity of the ball. (1)
- 3.2 Calculate the:
- 3.2.1 Height, h , of the school building (5)
- 3.2.2 Time it takes for the ball to reach the ground (4)

3.2.3 Velocity with which the ball strikes the ground (3)

3.3 Sketch a position versus time graph for the motion of ball from the moment it was released until it strikes the ground. Use the ground as the zero-reference point.

Indicate the following on the graph:

- The height from which the ball was released
- Time when the ball strikes the ground (3)

[16]

QUESTION 4

Two trolleys, **A** of mass 1 kg, and **B** of mass 2 kg, are held stationary on a smooth horizontal surface with a compressed spring between them, as shown in the diagram below. The spring is released and falls to the ground. Trolley **A** moves to the right at a constant velocity of $5,0 \text{ m}\cdot\text{s}^{-1}$ and collides with a wall.

Assume this is an isolated system.

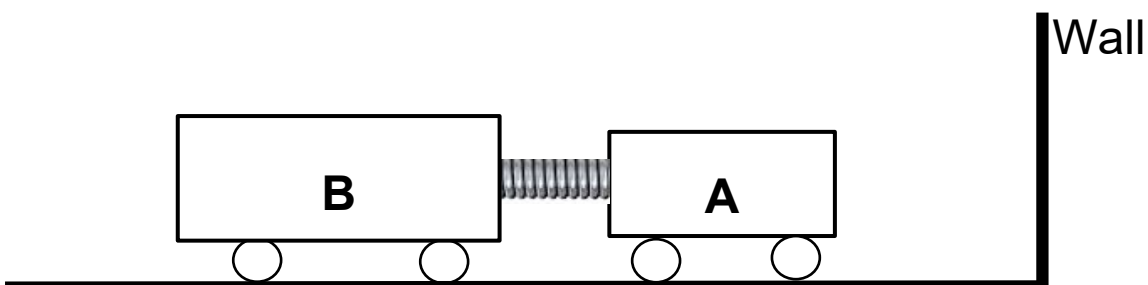

4.1 Define an *isolated system*. (2)

4.2 Calculate the velocity of trolley **B** immediately after the spring is released. (4)

4.3 The average force exerted by the wall on trolley **A** is 80 N and the collision of the trolley with the wall lasts 0,5 seconds.

Calculate the velocity with which trolley **A** moves away from the wall. (4)

4.4 A learner comments that the collision of trolley **A** with the wall is inelastic.

Briefly explain what is meant by an inelastic collision. (2)

[12]

QUESTION 5

A crate of mass 50 kg is at rest at point **A** which is at a vertical height of 5 m above the horizontal surface. The inclined surface makes an angle θ with the horizontal, as shown in the diagram below. When the crate is released, it slides down the incline and reaches point **B** at the bottom of the incline with a speed of $8 \text{ m}\cdot\text{s}^{-1}$. The incline exerts a constant frictional force of 72 N on the crate while it slides from **A** to **B**.

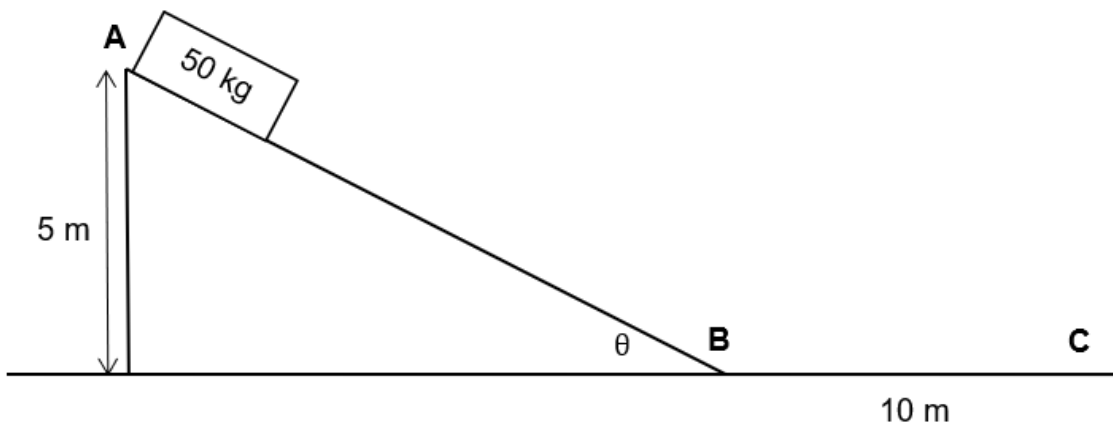

5.1 State the work-energy theorem in words. (2)

5.2 Use energy principles to calculate the angle θ . (6)

After passing point **B**, the crate slides along a rough horizontal surface, coming to rest at point **C**, which is 10 m away from point **B**.

5.3 Draw a free body diagram of all forces acting on the crate while it slides from **B** to **C**. (3)

5.4 Calculate the work done by the frictional force to bring the crate to rest. (4)

[15]

QUESTION 6

A police van with its siren on, travels at a constant speed between two observers, **A** and **B**. Observer **A** detects sound with a frequency of 545 Hz from the siren, while observer **B** detects a frequency of 615 Hz.

6.1 State the Doppler effect in words. (2)

6.2 In which direction is the police van moving?

Choose from TOWARDS OBSERVER **A** or TOWARDS OBSERVER **B**.

Give a reason for your answer. (2)

6.3 The speed of sound in air is $343 \text{ m}\cdot\text{s}^{-1}$. Calculate the frequency of the siren. (7)

6.4 Spectral lines of a certain gas observed from a distant star appear to be red shifted. Explain this observation by referring to the MOTION OF THE STAR and the FREQUENCY of the spectral lines. (2)

[13]

QUESTION 7

Two-point charges, **P** and **T**, are placed 0,03 m apart. The charge on **P** is $+36 \times 10^{-6} \text{ C}$ while **T** carries a charge of $16 \times 10^{-6} \text{ C}$ of UNKNOWN SIGN.



7.1 State Coulomb's law in words. (2)

7.2 Draw the electric field pattern around a positive charge. (3)

7.3 Calculate the magnitude of the force that charges **P** and **T** exert on each other. (3)

When a test charge is placed at point **X**, a distance **r** m to the right of charge **T** as shown in the diagram below, the test charge remains STATIONARY.



7.4 Write down the sign of the charge (POSITIVE or NEGATIVE) of **T**. Explain your answer. (3)

7.5 Calculate the distance **r**. (5)

[16]

QUESTION 8

Three resistors and an electrical device rated 16 W are connected to a battery of emf 36 V and unknown internal resistance r , as shown in the circuit diagram below. Ammeter A_2 reads 2 A when switch S is closed.

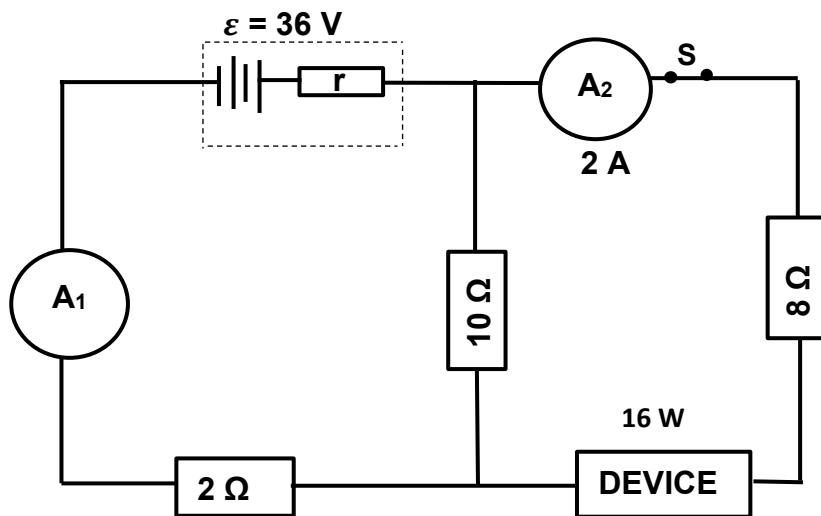

8.1 Define the term *emf* of a battery in words. (2)

8.2 Calculate the:

8.2.1 Resistance of the electrical device (3)

8.2.2 Current passing through the battery (5)

8.2.3 Internal resistance r of the battery (6)

8.3 The switch **S** is now opened. How will this affect the reading on ammeter **A₁**?

Choose from INCREASE, DECREASE or REMAIN THE SAME.

Explain your answer.

(2)
[18]

QUESTION 9

A coal power station uses AC generators to produce electricity.

- 9.1 State the energy conversion that takes place in a generator. (2)
- 9.2 Draw a sketch graph of emf generated versus time for two complete cycles for an AC generator. (2)
- 9.3 Alternating current is used for the long-distance transmission of electricity. Give a reason why AC is preferred over DC to transmit electricity over long distances. (1)
- 9.4 An electrical kettle is marked 220 V. What does the 220 V represent? (1)
- 9.5 A certain AC generator produces a peak current of 6,25 A when connected to an electrical kettle of resistance 45 Ω .

Calculate the:

- 9.5.1 Root mean square (rms) current (3)
- 9.5.2 Average power dissipated by the kettle when connected to this generator (3)

[12]

QUESTION 10

An investigation is done to determine the effect of the power of a light bulb on the current which is generated in a photo-electric cell. The apparatus used in this investigation is shown in the simplified diagram below. Ultraviolet light of wavelength 490 nm emitted by two bulbs, **A** and **B**, is shone onto the cathode of the photo-electric cell and the maximum speed of the ejected photo-electrons is measured.

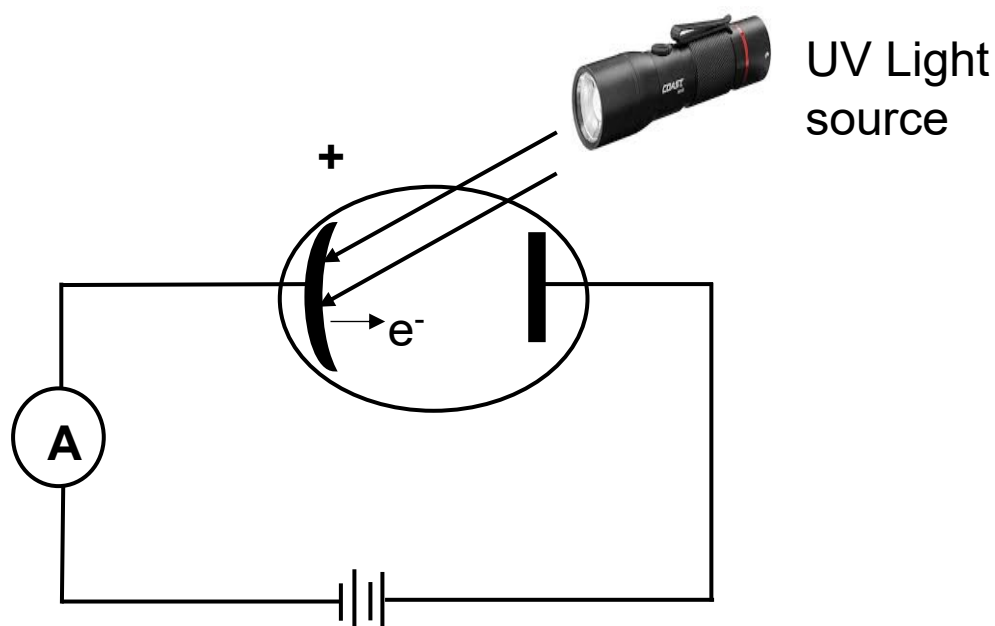

The results of their investigation are shown on the table below.

BULB	POWER OF LIGHT BULB	MAXIMUM SPEED OF PHOTO-ELECTRONS
A	100 W	$7,5 \times 10^5 \text{ m}\cdot\text{s}^{-1}$
B	200 W	$7,5 \times 10^5 \text{ m}\cdot\text{s}^{-1}$

10.1 Describe the term *photoelectric effect*.

(2)

10.2 Briefly explain why the power of the light bulbs does not affect the maximum speed of the ejected photo-electrons. (2)

10.3 Which ONE of the light bulbs, **A** or **B**, will produce the highest reading on the ammeter?

Explain your answer. (2)

10.4 Calculate the:

10.4.1 Energy of the ultraviolet photons (3)

10.4.2 Work function of the metal cathode (4)

[13]

TOTAL: 150

DATA FOR PHYSICAL SCIENCES GRADE 12
PAPER 1 (PHYSICS)
GEGEWENS VIR FISIESTE WETENSKAPPE GRAAD 12
VRAESTEL 1 (FISIKA)

TABLE 1: PHYSICAL CONSTANTS/TABEL 1: FISIESTE KONSTANTES

NAME/NAAM	SYMBOL/ SIMBOOL	VALUE/ WAARDE
Acceleration due to gravity / <i>Swaartekragversnelling</i>	g	$9,8 \text{ m}\cdot\text{s}^{-2}$
Universal gravitational constant <i>Universele gravitasiekonstant</i>	G	$6,67 \times 10^{-11}$ $\text{N}\cdot\text{m}^2\cdot\text{kg}^{-2}$
Speed of light in a vacuum / <i>Speed van lig in 'n vakuum</i>	c	$3,0 \times 10^8 \text{ m}\cdot\text{s}^{-1}$
Planck's constant / <i>Planck se konstante</i>	h	$6,63 \times 10^{-34} \text{ J}\cdot\text{s}$
Coulomb's constant / <i>Coulomb se konstante</i>	k	$9,0 \times 10^9 \text{ N}\cdot\text{m}^2\cdot\text{C}^{-2}$
Charge on electron / <i>Lading op elektron</i>	e	$-1,6 \times 10^{-19} \text{ C}$
Electron mass / <i>Elektronmassa</i>	m_e	$9,11 \times 10^{-31} \text{ kg}$
Mass of earth / <i>Massa op aarde</i>	M	$5,98 \times 10^{24} \text{ kg}$
Radius of earth / <i>Radius van aarde</i>	R_E	$6,38 \times 10^6 \text{ m}$

TABLE 2: FORMULAE/TABEL 2: FORMULES**MOTION/BEWEGING**

$v_f = v_i + a \Delta t$	$\Delta x = v_i \Delta t + \frac{1}{2} a \Delta t^2$ <i>or/of</i> $\Delta y = v_i \Delta t + \frac{1}{2} a \Delta t^2$
$v_f^2 = v_i^2 + 2a\Delta x$ <i>or/of</i> $v_f^2 = v_i^2 + 2a\Delta y$	$\Delta x = \left(\frac{v_i + v_f}{2} \right) \Delta t$ <i>or/of</i> $\Delta y = \left(\frac{v_i + v_f}{2} \right) \Delta t$

FORCE/KRAG

$F_{\text{net}} = ma$	$p = mv$
$f_s^{\text{max}} = \mu_s N$	$f_k = \mu_k N$
$F_{\text{net}} \Delta t = \Delta p$ $\Delta p = mv_f - mv_i$	$w = mg$
$F = \frac{Gm_1m_2}{d^2}$	$g = G \frac{M}{d^2}$

WORK, ENERGY AND POWER/ARBEID, ENERGIE EN DRYWING

$W = F \Delta x \cos \theta$	$U = mgh$ or/of $E_p = mgh$
$K = \frac{1}{2}mv^2$ or/of $E_k = \frac{1}{2}mv^2$	$W_{\text{nett}} = \Delta K$ or/of $W_{\text{nett}} = \Delta E_k$ $\Delta K = K_f - K_i$ or/of $\Delta E_k = E_{kf} - E_{ki}$
$W_{\text{nc}} = \Delta K + \Delta U$ or/of $W_{\text{nc}} = \Delta E_k + \Delta E_p$	$P = \frac{W}{\Delta t}$
$P_{\text{ave}} = Fv$	

WAVES, SOUND AND LIGHT/GOLWE, KLANK EN LIG

$v = f \lambda$	$T = \frac{1}{f}$
$f_L = \frac{v \pm v_L}{v \pm v_s} f_s$ $f_L = \frac{v \pm v_L}{v \pm v_b} f_b$	$E = hf$ or/of $E = h \frac{c}{\lambda}$
$E = W_0 + E_{k(\text{max})}$ where/waar $E = hf$ and/en $W_0 = hf_0$ and/en $E_{k(\text{max})} = \frac{1}{2}mv_{\text{max}}^2$ or/of $K_{(\text{max})} = \frac{1}{2}mv_{\text{max}}^2$	

ELECTROSTATICS/ELEKTROSTATIKA

$F = \frac{kQ_1Q_2}{r^2}$	$E = \frac{kQ}{r^2}$
$V = \frac{W}{q}$	$E = \frac{F}{q}$
$n = \frac{Q}{q_e}$	

ELECTRIC CIRCUITS/ELEKTRIESE STROOMBANE

$R = \frac{V}{I}$	$\text{emf } (\varepsilon) = I(R + r)$
$R_s = R_1 + R_2 + R_3 + \dots$ $\frac{1}{R_p} = \frac{1}{R_1} + \frac{1}{R_2} + \dots$	$Q = I\Delta t$
$W = Vq$ $W = VI\Delta t$ $W = I^2R\Delta t$ $W = \frac{V^2\Delta t}{R}$	$P = \frac{W}{\Delta t}$ $P = VI$ $P = I^2R$ $P = \frac{V^2}{R}$

ALTERNATING CURRENT/WISSELSTROOM

$I_{\text{rms}} = \frac{I_{\text{max}}}{\sqrt{2}} \quad / \quad I_{\text{wgk}} = \frac{I_{\text{maks}}}{\sqrt{2}}$ $V_{\text{rms}} = \frac{V_{\text{max}}}{\sqrt{2}} \quad / \quad V_{\text{wgk}} = \frac{V_{\text{maks}}}{\sqrt{2}}$	$P_{\text{average}} = V_{\text{rms}} I_{\text{rms}} \quad /$ $P_{\text{gemiddeld}} = V_{\text{wgk}} I_{\text{wgk}}$ $P_{\text{average}} = I_{\text{rms}}^2 R \quad /$ $P_{\text{gemiddeld}} = I_{\text{wgk}}^2 R$ $P_{\text{average}} = \frac{V_{\text{rms}}^2}{R} \quad / \quad P_{\text{gemiddeld}} = \frac{V_{\text{wgk}}^2}{R}$
---	---